

Have your Cake and a Nice Cuppa

Foundation Paper Piecing patterns to make postcards or rectangular quilt blocks

Finished size of each design 6 x 4 inches

I don't intend to go into the whole business of foundation paper piecing and the various methods that different people have devised. There are many excellent tutorials and videos on-line (my favourite is shown at the bottom of the page). So, if you have not done any before, have a look at them and HAVE A GO!



PATTERNS: Print the patterns on the following page onto photocopier paper (the cheaper the better - it is easier to see through and tears much better, when perforated, than the expensive kind.)

FABRICS: you will need approximately 10 x 10 inches of background fabric for each block, plus 5 x 4 inch scraps and 1 inch wide strips of various other fabrics

Remember the basic rules of all foundation paper piecing:

- The printed image is the reverse of the stitched one ie. it appears back-to-front
- Fabric goes on BLANK side of the foundation paper
- Only the first piece of fabric is placed face up
- All other pieces of fabric are placed face down ie. Right Sides Together
- Always work in numerical order – note which fabric is used in each section
- Stitch directly ON the line with a very short stitch adding a few stitches to each end of the marked line
- Trim excess fabric and thread ends as you work

Building Postcards:

Additional requirements: craft vilene (stiff) 6 x 4 inches, plus calico 6½ x 4½ inches

Press your finished pieced block and the calico before starting – DO NOT PRESS THE VILENE

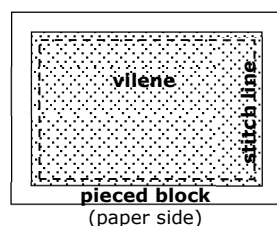

Step 1: Lay a piece of Vilene on the paper side of your pieced block, lined up with the solid line on the pattern and stitch in place close to the edge.

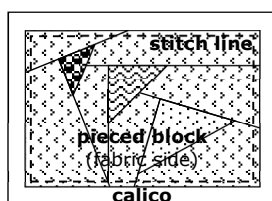

Step 2: Trim the pieced block to the same size as the Vilene and lay it Vilene side down on the calico. Again stitch in place close to the edge.

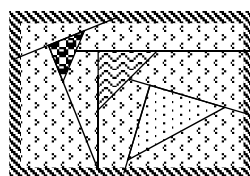

Step 3: Trim the calico to the size of the postcard and zig-zag stitch over the edge of the trimmed postcard going all round twice.

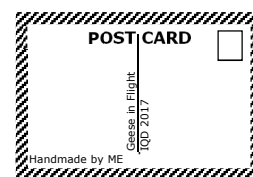

Step 4: Write on the calico side with a fine permanent marker – include your details & information about the design plus the usual POSTCARD stuff.

SEND IT THROUGH THE POST: Remember to use a LARGE LETTER stamp if you have attached beads, buttons, several layers of fabric or trimmings (anything thicker than ¼ inch).

Foundation paper piecing tutorial:

<http://www.michaelannmade.com/2015/06/foundation-paper-piecing-crash-course.html>

A Nice Cuppa

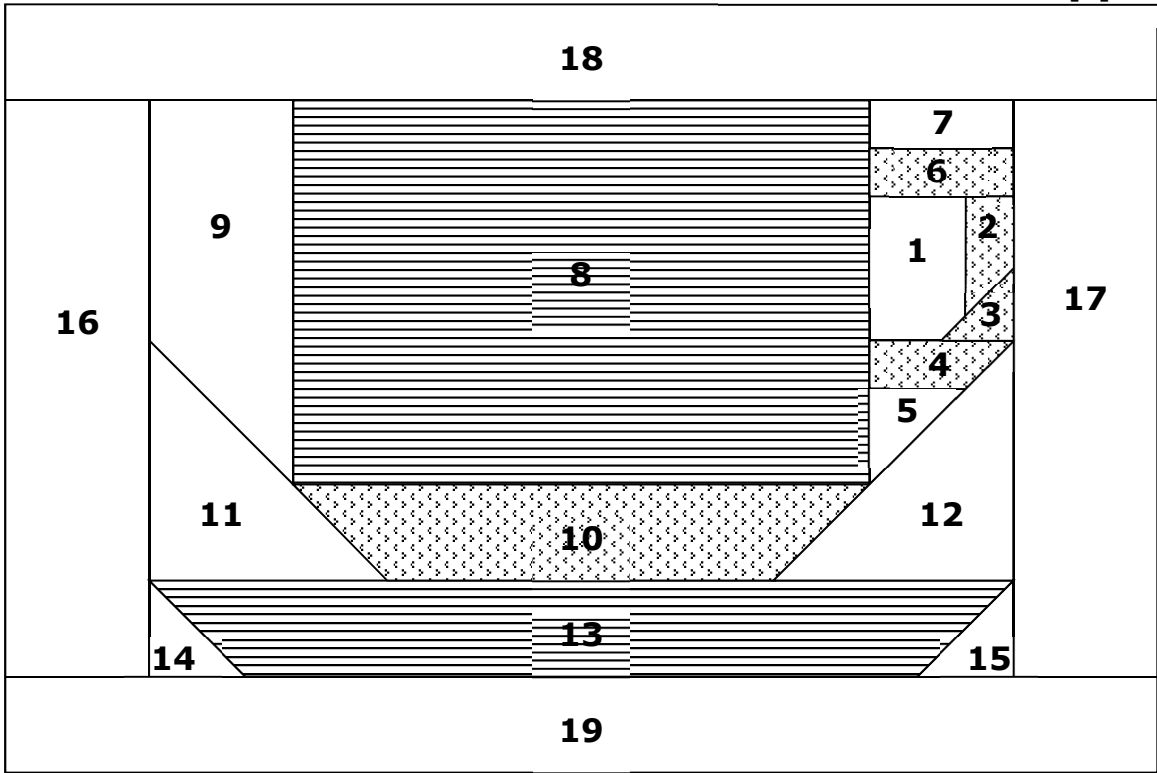

© Helen Butcher 2017 - www.littlepatchpockets.co.uk

Have your Cake

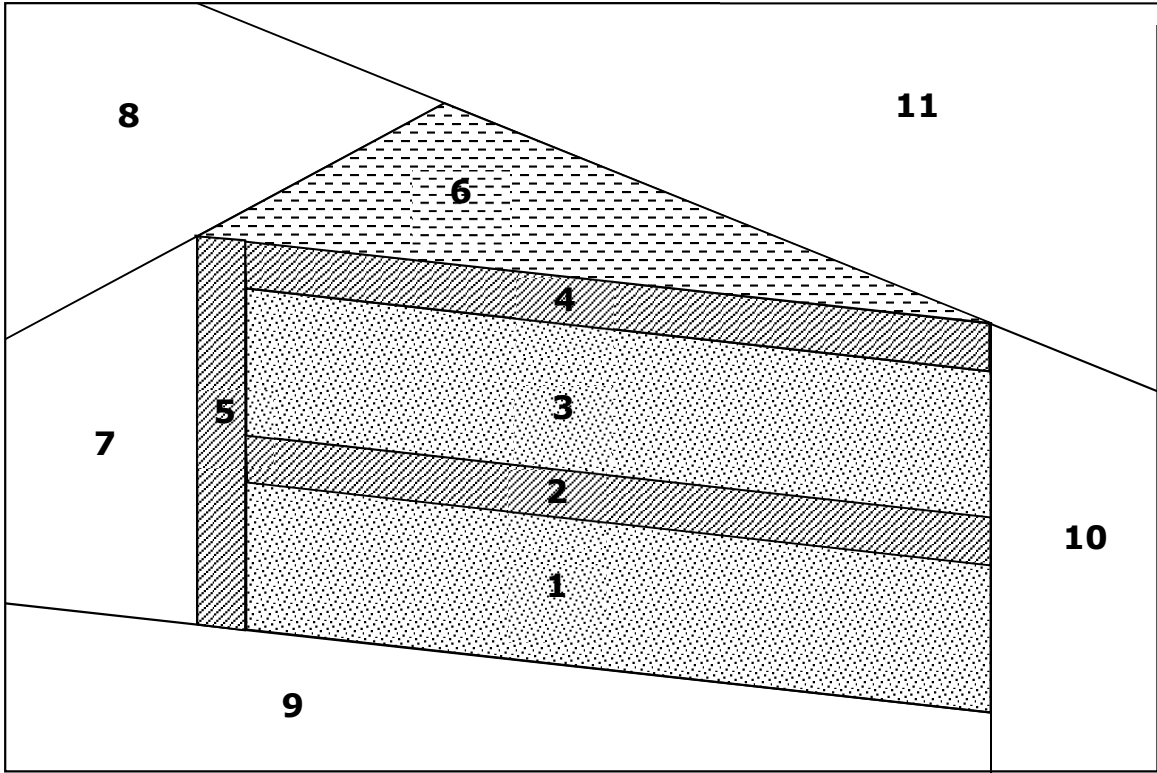

© Helen Butcher 2017 - www.littlepatchpockets.co.uk